



PO Box 5171
336•884•8822

High Point, NC 27262
Fax: 336•884•8835

www.ArtisticQuiltingInc.com

4/10/15

QUILTING STANDARDS

Quilting will irreparably alter your fabric, therefore it is important that you understand the industry standards, the available options, the necessary limitations, and the possible consequences.

We are proud to offer a broad selection of quilting styles and patterns. Please see our “Quilting Styles and Options” page for a description and pictures of each.

All of our quilting is hand guided by skilled craftsmen on industrial quilting machines, therefore the custom look you desire has inherent imperfections. To maintain a regularity of the quilting and to keep the unique blemishes from appearing as flaws, we provide the following information and guidelines:

- The quilting process causes fabric to draw in 10% in each direction. Allowances for this shrinkage have been made in the yardage charts found in the various product pamphlets. You are responsible for making these allowances when sending us roll or cut fabric for quilting only.
- All quilting includes lining appropriate for the final use that you designate (bedspread or upholstery).
- The fiber batting used as filler in our quilting is 100% polyester garnetted fiber.
- Fiber weights include Ultra Thin, 4 oz, 6 oz, 9 oz, and 12 oz; one of which will suit your needs. Our standard fiber weight for coverlets and spreads is 6 oz, with the 9 oz being standard for comforters and for upholstery.
- Ultra Thin and 4 oz are great for light weight spreads, summer coverlets, and quilted duvets. The heavier weight fills give the quilting a puffier look, but do add weight and bulk, which may be a consideration for your client. The 12 oz fiber is reserved for comforters only. No matter which fiber fill weight you choose, the more quilting utilized, such as a small vermicelli or an “A” Grade, the flatter the finished product.
- Fiber weight for upholstery is recommended to be 9 oz, as it will hold up to the repetitive compression with use. Ultra thin can be used on skirts on upholstered sofas and chairs, and for quilted table rounds.
- The fabric, fiber, and lining must be pinned together before quilting to keep the three layers from shifting and pleating while being quilted. We call this pinning process “Cottoning Up”, referring back to an era when the batting was actually cotton.

- For most fabrics, the pins used to “Cotton Up” do not create any problem, as the pinholes disappear as soon as the pins are removed. For other fabrics, such as lacquered chintz, the pinholes will not disappear, so we pin in darker areas and along quilt lines, where the pinholes will not be prominent. Leathers cannot be pinned, we must staple the leather, fiber, and lining together around the edges.
- Even with substantial pinning during the Cotton Up process, small pleats may appear on the lining side of your piece.
- Outline quilting and many of the Freehand patterns are the perfected art of our quilters’ talents. Since each piece is handcrafted, no two are exactly the same, but all provide the custom appearance you desire. Many times, mini-prints are arranged in such a way that the pattern can be followed to create a geometric outline of the layout. This type of Freehand quilting offers the same benefits as Outline quilting because it enhances the existing design of the fabric.
- Other Freehand patterns, such as channels, blocks, diamonds, shells, to mention a few, require that the pattern be marked on the fabric with a disappearing chalk. Residue of the chalk may be visible for a few days after quilting, but the chalk will disappear over time.
- Parallel lines, such as channels, blocks, or diamonds, are set at least 4” apart to minimize any visual “defects” of the craft. The spacing of quilt lines can vary from the 4” minimum on up, according to the proportions you feel appropriate. The spacing is then calculated to the nearest multiple that divides evenly between the seams of the spread so that the seams can be concealed with the quilting process. This can only be accomplished for the seams on the face side of the quilted piece.
- Diamond sizes are referenced with the width, point-to-point, by the length, point-to-point. Our standard size for a harlequin diamond is 6” wide x 8” tall (the smallest is 5” x 7”). There is no standard size for a square or baseball diamond, but 4½” x 4½” is the smallest size we can quilt.

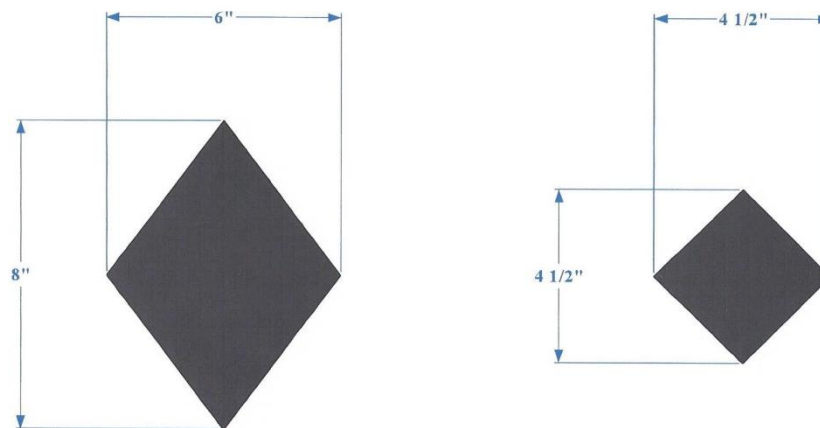

[Click for enlarged view](#)

- Channels and Harlequin Diamonds will be marked to run vertically on the spread (head to foot) and on upholstery (top to bottom) and up the roll on cut panels unless specifically detailed in your Purchase Order. Channels will run head to foot on the side drops as well, even on fitted spreads with separate drops.
- Fabric size is limited to 126” (3.5 yards) in length to maintain the quality of the quilting. Because the quilting is hand guided, and not on a loom, the quilters must be able to hold all of the fabric and batting in their laps and work over the materials as they guide each stitch. The more fabric that is piled in their laps, the more cumbersome it is to maintain accurate stitching.

- Quilting for upholstery is a better value and of better quality when each piece is pre-cut to the over-sized pattern (adding about 3” - 4” all around). Each piece should be marked on the reverse side with a “T” to indicate the “top” of the fabric so that we will know the intended direction that the piece will be used.
- After the upholstery fabric is quilted, mark the piece per your pattern. At every intersection of the quilt lines with the pattern marks, bond the stitching before cutting by placing a drop of Fray Block, Fray Check, or similar products, onto the stitching at the line. Allow to dry thoroughly before cutting. This will prevent raveling of the stitching after the pattern line is cut.
- Leather size is limited to pieces no bigger than 1.5 square yards. Leather can only be quilted with straight lines, forming channels, blocks, or diamonds.
- Hand guided quilting uses thread matched to the predominate color of your face fabric as well as a lock stitch technique to prevent raveling. For fabrics, the thread is a poly-cotton Tex-27. For leathers, the thread is nylon. We use a white, cream, or gray bobbin thread when we can, which will blend with the lining. With darker color face fabrics, we try to use a lighter tone of that dark color on the bobbin so that the thread on the lining will not be too bold. If this is a concern for your client, you may want to provide a darker lining fabric that will not show the contrast.
- Stitch length in hand guided quilting cannot be set on the machine as it can for normal sewing, so it is impossible for us to maintain a given stitch length. Our quilting stitches are dictated by the speed the quilter pulls the piece through the machine. On Outline and Freehand patterns that are free-flowing, the stitches may be further apart as the quilter has more leeway in the speed. On straight lines, where more diligence and care must be taken to make a straight line, the stitches may be closer.
- Taking the quilting stitches out of an entire quilted piece is not a viable option due to the wear and tear it will have on the fabric. Therefore it is essential that you understand the industry standards, the available options, the necessary limitations, and the possible consequences before having your fabric quilted.

I understand and agree to the limitations of having my fabric quilted:

Date: _____

Name: _____ Signature: _____